

Unit 6 Review - Circles

NAME _____

Arc Length and Area of a Sector

Find each requested measurement.

1. central angle = 67° , radius = 3 m
Find area of sector.

3. arc length = 17 in, radius = 4 in
Find central angle.

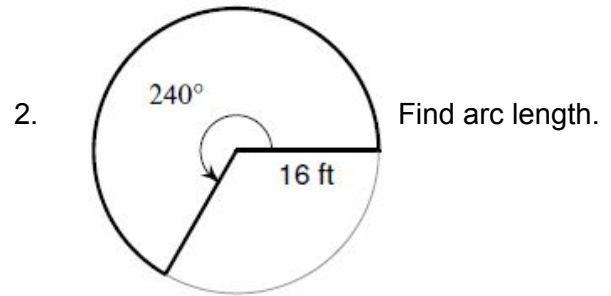

4. area of sector = 34 cm^2 , central angle = 105°
Find radius.

Equation of a Circle

Determine the center and radius of each circle.

5. $(x - 5)^2 + (y + 6)^2 = 9$

6. $(x - 9)^2 + y^2 = 60$

7. $x^2 + y^2 + 8x - 4y + 11 = 0$

8. $x^2 + y^2 + 24x + 10y + 160 = 0$

Inscribed Angles

Solve for each indicated measurement.

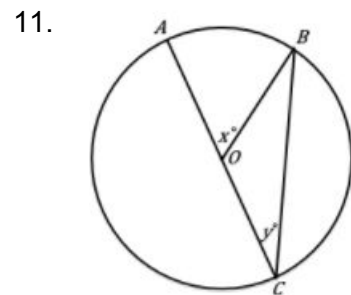
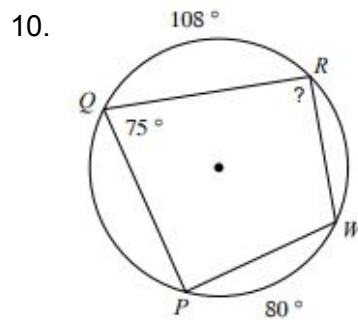
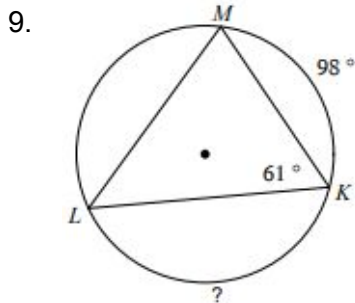

12.

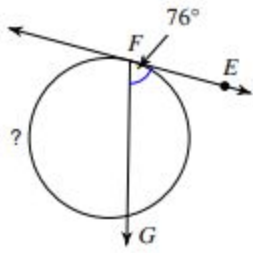

13. Find arc MRF.

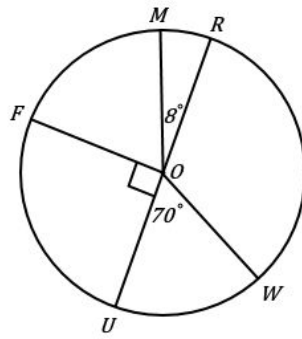

Chords

Solve for each indicated measurement.

14. Find length of AB

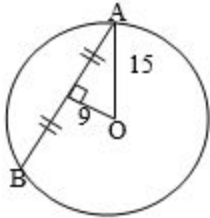

15.

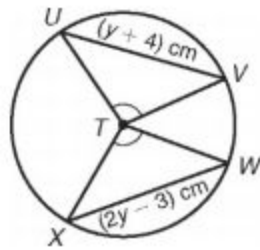

16.

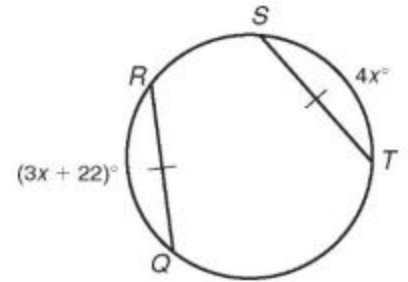

17.

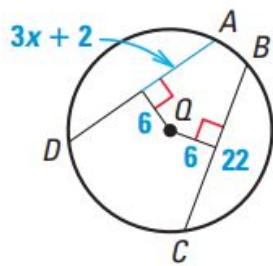

18.

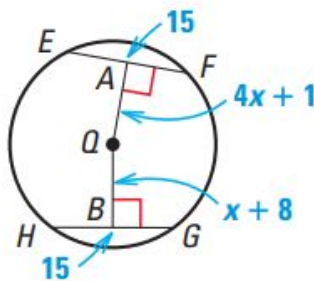

Tangents

Solve for the variable.

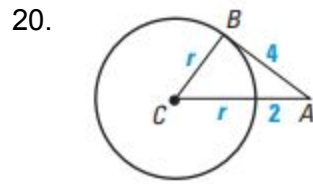
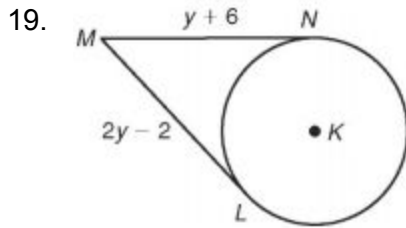

21. Find perimeter.

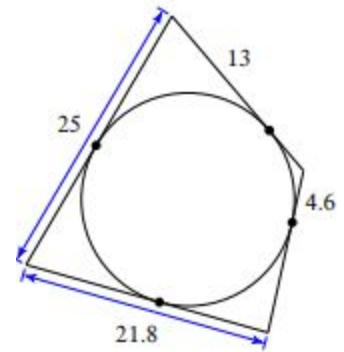

Angles Formed By Secants, Tangents, and Chords

Solve for x .

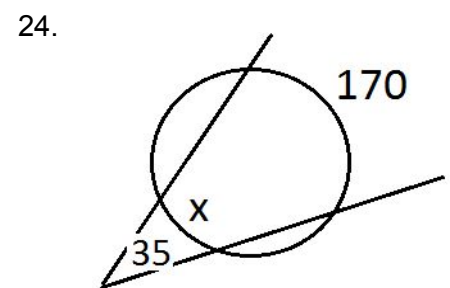
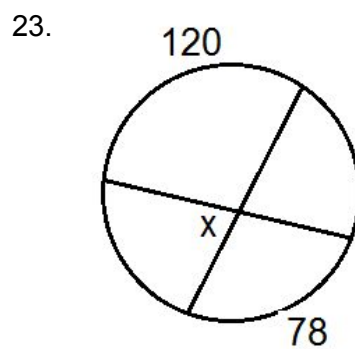
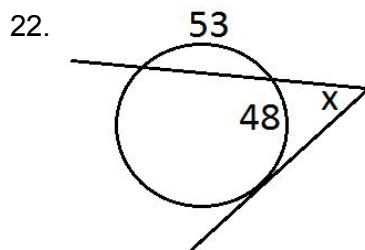

Lengths Formed By Secants, Tangents, and Chords

Solve for x .

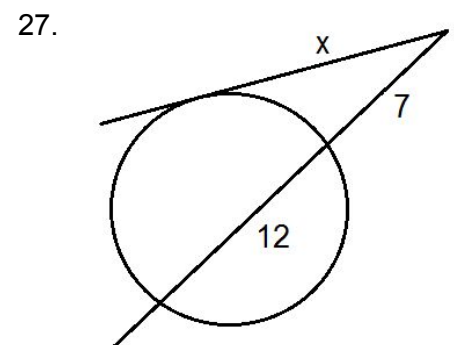
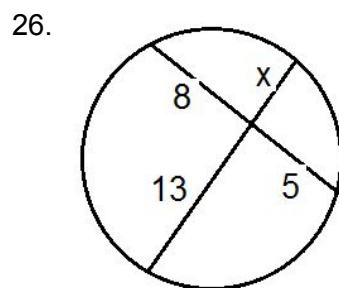
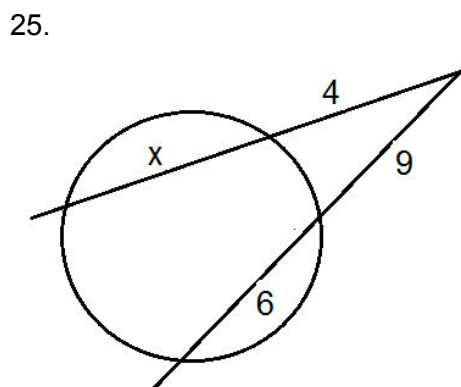

Fun with Factoring!!

Factor.

28. $4x^2 - 9$

29. $-6g^7 + 7g^4$

30. $w^2 - 5w + 6$

31. $5a^3 - 10a^2 - 15a$

32. $3x + 2$

33. $20x^2 + 13x + 2$