

Shapes and Nets

Determine the 3D figure formed by the net.

1.

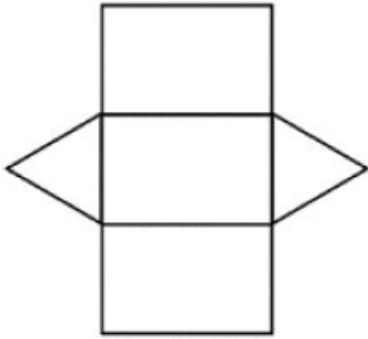

2.

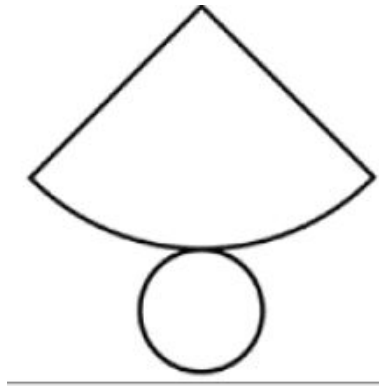

3.

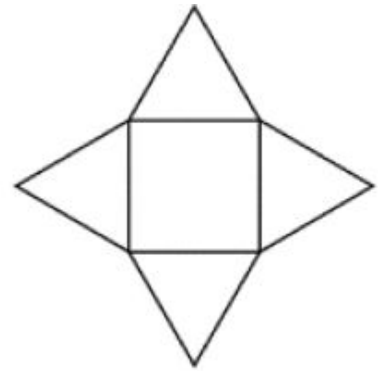

Surface Area and Volume

Determine the surface area of each figure.

4.

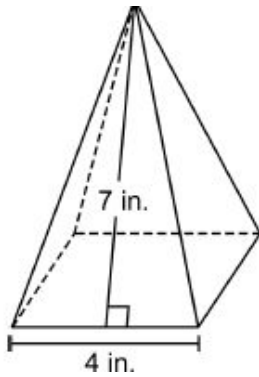

5.

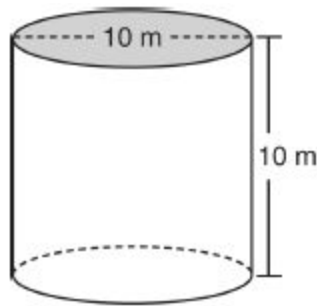

6.

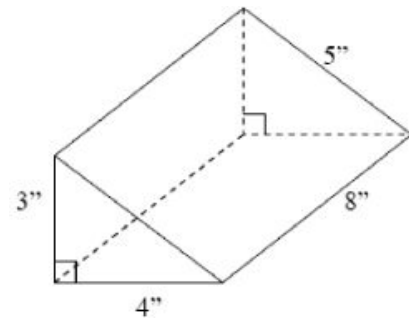

7.

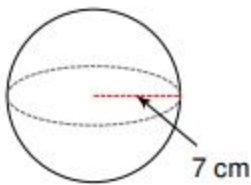

8.

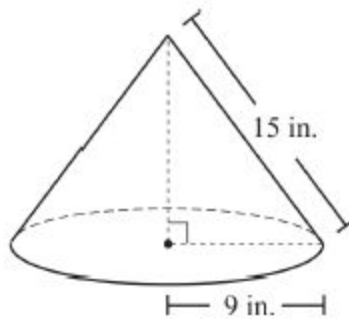

Determine the volume of each figure.

9.

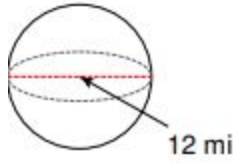

10.

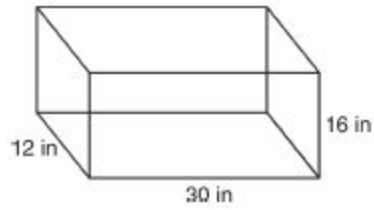

11.

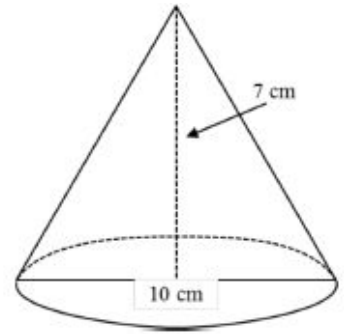

12.

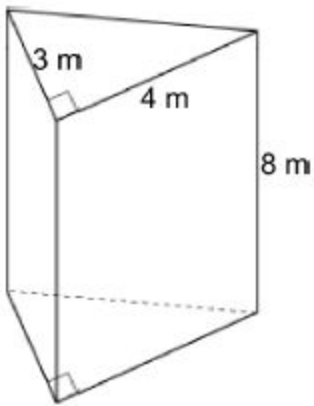

13.

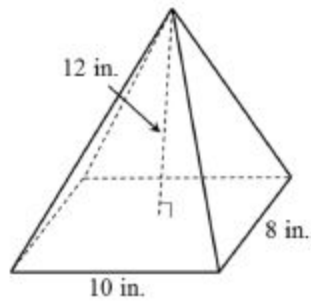

Cross-Sections

Describe the cross-section formed by the 3D figure and the plane.

14.

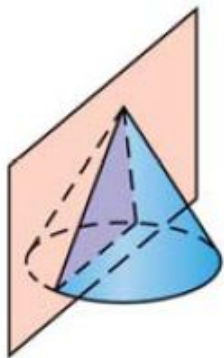

15.

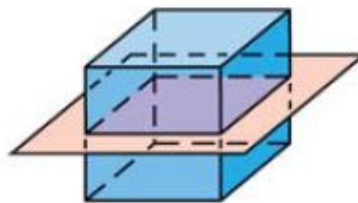

16.

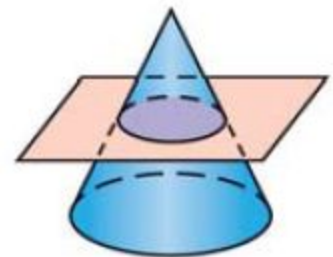

Rotations of 2D Figures to Create 3D Figures

Describe the 3D figure created by rotating the 2D figure around the given line.

17.

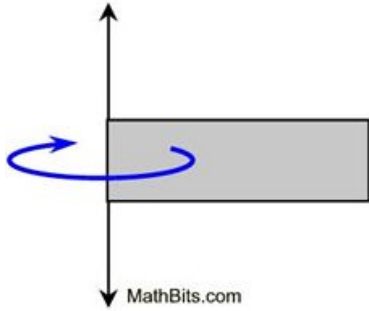

18.

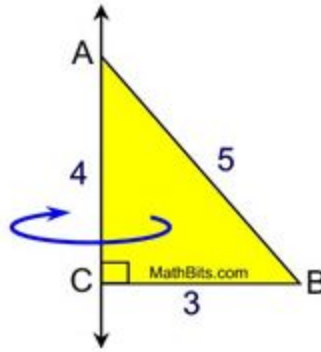

19.



20.

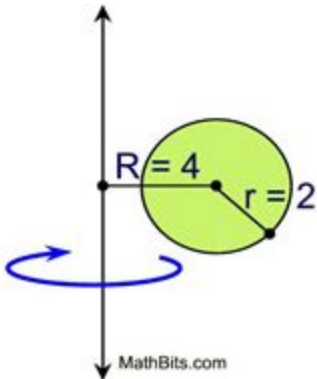

21.



Geometric Modeling

22. Determine the surface area of the cover of a textbook that has a length of 11 inches, a width of 8 inches, and a height of 3 inches.

23. Judy has a cylindrical jar with a radius of 6 cm and a height of 10 cm. She puts 20 spherical marbles, each with a radius of 2 cm, into the jar. The rest of the space in the jar is filled with sand. Determine the volume of the sand.

24. Brittany is going to cover the label on a Pringles can and decorate it for Easter. The can has a diameter of 4.5 in. and a height of 14 in. She only needs to cover the label, not the top or bottom of the can, what is the minimum amount of paper needed?

25. If one guppy requires 5 liters of water to live happily, what is the maximum number of guppies that should be kept in this aquarium?
($1000 \text{ cm}^3 = 1 \text{ liter}$)

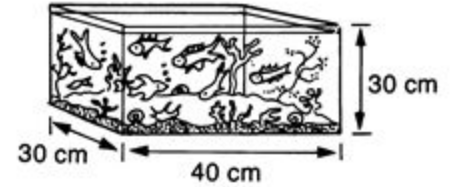

26. Pedro created a cone-shaped cup out of paper. If his cup has a radius of 3 inches and a slant height of 5 inches, how much paper did he use?

27. A section of concrete pipe 30 m long has an inside diameter of 1.2 m and an outside diameter of 1.8 m. What is the volume of concrete in this section of pipe?

